

GMK3055

product guide

features

- 32-141 ft. (9.7-43 m) 6-section full power boom
- Patented TWIN-LOCK™ boom pinning system
- 28.5-49.2 ft. (8.7-15 m) bifold lattice swingaway, hydraulic luffing or manual offset
- 25,500 lb. (11 600 kg) counterweight with hydraulic removal system
- 349 hp (260 kW) Mercedes OM501LA 6 cylinder turbo-charged diesel engine. ZF, AS Tronic transmission
- Independent hydro-pneumatic MEGATRAK™ suspension
- All wheel steering



contents

Features	2
Specifications	3
Dimensions	5
Travel Proposal	6
Working Range	7
Main Boom Charts	8
Working Range (swingaway)	11
Manual Offset 25,500 counterweight	12
Manual Offset 16,700 counterweight	14
Luffing Offset 25,500 counterweight	16
Luffing Offset 16,700 counterweight	20

All Terrain Crane

features

2



Mercedes-Benz OM501LA
 349 bhp (260 kW) @ 1800 rpm
 1276 ft./lb. torque (1730 Nm) @ 1080 rpm



ZF AS Tronic
 12 speeds fwd, 2 rev

TWIN-LOCK™
 Boom pinning
 mechanism
 automatically pins
 the sections in
 position using two
 horizontal large
 diameter boom
 pins

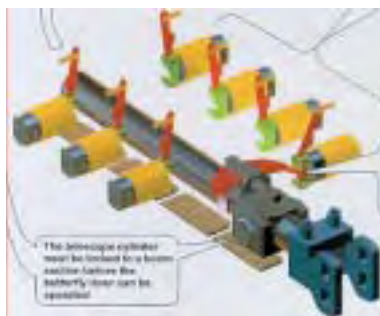

MEGATRAK™
 Independent
 suspension and
 all wheel steer
 system allows
 wheels to
 remain on the
 ground at all
 times so
 stresses and
 weight are not
 continually
 transferred
 between axles

LUFFING BI-FOLD SWINGAWAY
 Hydraulically offset lattice bi-fold swingaway
 lets the operator set the offset from 0°-40°
 while under load, from the superstructure
 cab

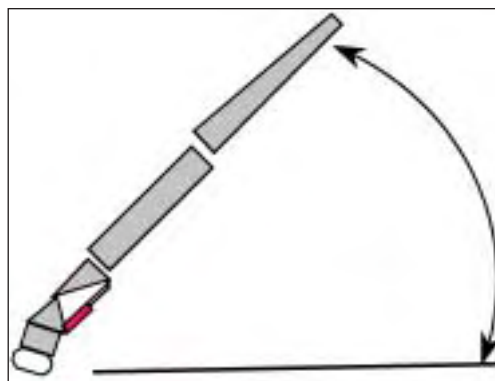

specifications

3

Superstructure

Boom

32 ft. - 141 ft. (9.7 m - 43 m) six section, full power boom with patented TWIN-LOCK™ boom pinning system. Maximum tip height: 150 ft. (45.8 m).

Boom Nose

Five nylatron sheaves, mounted on heavy duty tapered roller bearings with removable pin-type rope guards. Quick reeve boom nose. Removable auxiliary boom nose with removable pin type rope guard.

Boom Elevation

Single lift cylinder with safety valve provides boom angle from -2.7° to +82.8°.

Hydraulically Offsettable Lattice Extension

28.5 ft. – 49.2 ft. (8.7 m - 15 m) bifold lattice swingaway extension **hydraulically offsettable** and luffing under load: 0° - 40°. Controlled from the crane cab. Maximum tip height: 199 ft (60.7 m)

* Offsettable Lattice Extension

28.5 ft. – 49.2 ft. (8.7 m - 15 m) bifold lattice swingaway extension manually offset: 0°, 20° or 40°. Maximum tip height: 199 ft (60.7 m)

Load Moment & Anti-Two Block System

Load moment and anti-two block system with audio/visual warning and control lever lockout provides electronic display of boom angle, length, radius, tip height, relative load moment, maximum permissible load, load indication and warning of impending two-block condition.

Cab

All aluminum construction cab with acoustical lining, tinted safety glass, adjustable operator's seat with hydraulic suspension, sliding windows in side and cab rear, hinged front window with wiper, sunvisor and window shade. Other features include diesel heater/defroster, armrest integrated crane controls, and ergonomically arranged instrumentation.

Crane Control System

Full electronic control of all crane movements using electrical control levers with automatic reset to zero. Controls are integrated with the LMI and engine management system by CAN-BUS. ECOS system with graphic display.

Swing

Axial piston fixed displacement motor and planetary gear box. Infinitely variable to 2.5 rpm. Holding and service brake.

Counterweight

25,500 lbs. (11 600 kg) consisting of 14,500 lb. (6 600 kg) bolted to the turntable, 1 X 4409 lb. (2 000 kg) and 3 X 2204 lb. (1 000 kg) sections with hydraulic installation/removal system. Controlled from the superstructure cab.

Hydraulic System

2 separate circuits, 1 axial piston variable displacement pump (load sensing) with electronic power limiting control and 1 gear pump for swing.

Dual thermostatically controlled oil coolers keep oil at optimum operating temperature.

Tank capacity: 159 gal. (600 l)

Hoist

Main and auxiliary hoist are powered by axial piston motor with planetary gear and brake. "Thumb-thumper" hoist drum rotation indicator alerts operator of hoist movement.

	Main	Auxiliary
Line length:	558 ft. (170 m)	558 ft. (170 m)
Rope diameter:	16 mm	16 mm
Line speed:	394 ft./min. (120 m/min)	394 ft./min. (120 m/min)
Line pull:	11,240 lbs. (50 kN)	11,240 lbs. (50 kN)

*Denotes optional equipment

GMK3055

specifications

4

Carrier

Chassis

Box type, torsion resistant frame is fabricated from high strength steel.

Outrigger System

Four hydraulic single stage outrigger beams with vertical cylinders and outrigger pads, 19.7" (500 mm) square .
Outriggers can be set in 3 positions:

Full	- 20.3' (6.2 m)
Partial	- 14.4' (4.4 m)
Retracted	- 7.6' (2.3 m)

Independent horizontal and vertical movement controlled from each side of carrier and the superstructure cab. Electronic crane level indicators.

Engine

Mercedes-Benz OM 501 LA six cylinder, water cooled, turbo-charged, with 349 bhp (260 kW) @ 1800 rpm. Max. torque 1,276 ft./lb. (1 730 Nm) @ 1080 rpm. Compression and exhaust brakes. Engine emissions: EUROMOT/EPA/CARB (off road)

Fuel Tank Capacity

79 gallons (300 L).

Transmission

ZF, AS Tronic, 12 speeds forward, 2 reverse.

Drive/Steer

6X4X6

Axles

1st axle line – drive/steer

2nd axle line – steer (optional drive)

3rd axle line – drive/steer (connects for all wheel steer)

Drive axles with planetary hub reduction and center mounted gearing. Inter-axle and cross axle differential locks.

Suspension

Grove exclusive MEGATRAK suspension. Independent hydro-pneumatic system acting on all wheels with hydraulic lockout. Suspension can be raised 6.5" (170 mm) or lowered 5.1" (130 mm) both longitudinally and transversely. Features an automatic leveling system for highway travel.

Tires

6 tires, 20.5R25

Steering

Dual circuit, hydraulic power assisted steering system. Transfer case mounted, ground driven emergency steering pump. Axles 1 and 2 steer on highway. Separate steering of the 3rd axle for all wheel and crab steering, controlled by an electric rocker switch.

Brakes

Service brakes: pneumatic dual circuit acting on all wheels.
Parking brake: pneumatically operated spring loaded brake acting on axle lines 1 and 3.
Air dryer.

Cab

Two-man, aluminum construction with the following features: safety glass, driver and passenger seats with hydraulic suspension, engine-dependent hot water heater, complete instrumentation and driving controls. Cab tilts forward for easy engine access.

Electrical System

24V system with three phase alternator, 28V/100A
2 batteries, 12V/170 Ah

Maximum Speed

50 mph (80 kph) 14.00 tires
53 mph (85 kph) 16.00/20.5 tires

Gradeability (Theoretical)

82% - 14.00 tires
72% - 16.00/20.5 tires

Miscellaneous Standard Equipment

Spare tire and wheel with carry bracket; work light; tool kit; fire extinguisher; auxiliary boom nose; radio /CD player in carrier cab, heated rear view mirrors, and cruise control.

Optional Equipment

- *Worklights, mounted on boom base section
- *Wind speed indicator
- *Tiltable superstructure cab
- *Timer for diesel heater
- *Radio/CD player for superstructure cab
- *Stainless steel exhaust system with spark arrestor
- *Air conditioning
- *Hook blocks/headache ball
- *14.00R25 tires (vehicle width 8.4 ft.(2.55 m)
- *16.00R25 tires (vehicle width 9.0 ft.(2.75 m)
- *6X6X6 drive/steer
- *Electric driveline retarder
- *Engine independent diesel cab heater, with engine pre-heater
- *Strobe light
- *Cab mounted work light
- *Working range limiter
- *Worklights for outriggers
- *Data logger

*Denotes optional equipment

GMK3055

GROVE.

dimensions

5

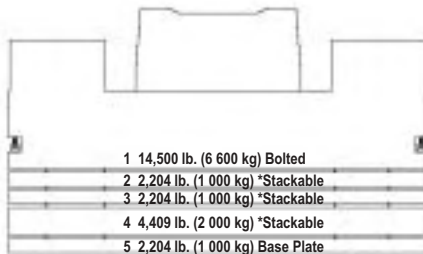
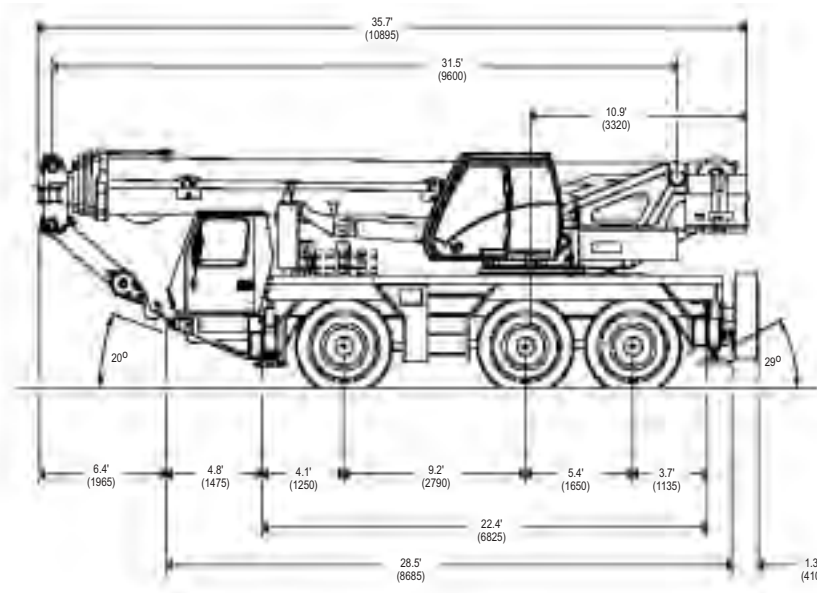
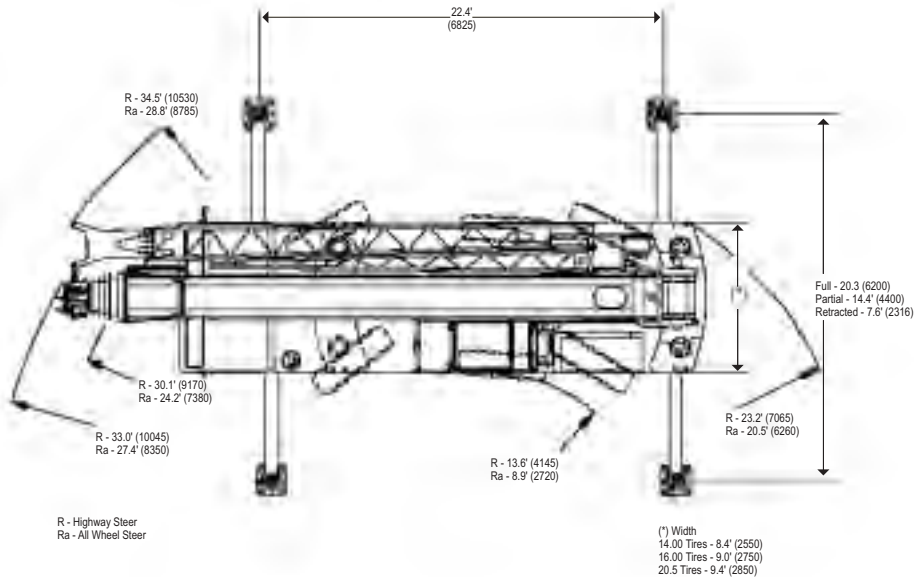

	1	2	3	4	5
Counterweight Configuration					
14,500 lbs (6 600 kg)	●				
16,700 lbs (7 600 kg)	●				●
18,900 lbs (8 600 kg)	●	●			●
21,100 lbs (9 600 kg)	●	●	●		●
23,300 lbs (10 600 kg)	●	●		●	●
25 500 lbs (11 600 kg)	●	●	●	●	●

Load Chart Configuration - 360°						
Counterweight	25,500	23,300	21,100	18,900	16,700	14,500
Main Boom	✘ ■	✘ ■	✘ ■	✘ ■ ●	✘ ■ ● □ ○	✘ ■ ● □ ○
28.5 ft. Swingaway	✘ ■	✘ ■	✘ ■	✘ ■	✘ ■	✘ ■
49.2 ft. Swingaway	✘ ■	✘ ■	✘ ■	✘ ■	✘ ■	✘ ■

Outrigger Span Rubber 20.3 ft. = ✘ 14.4 ft. = ■ 7.6 ft. = ●
P&C = □ 360° = ○

GMK3055

travel proposal

Boom over front

6

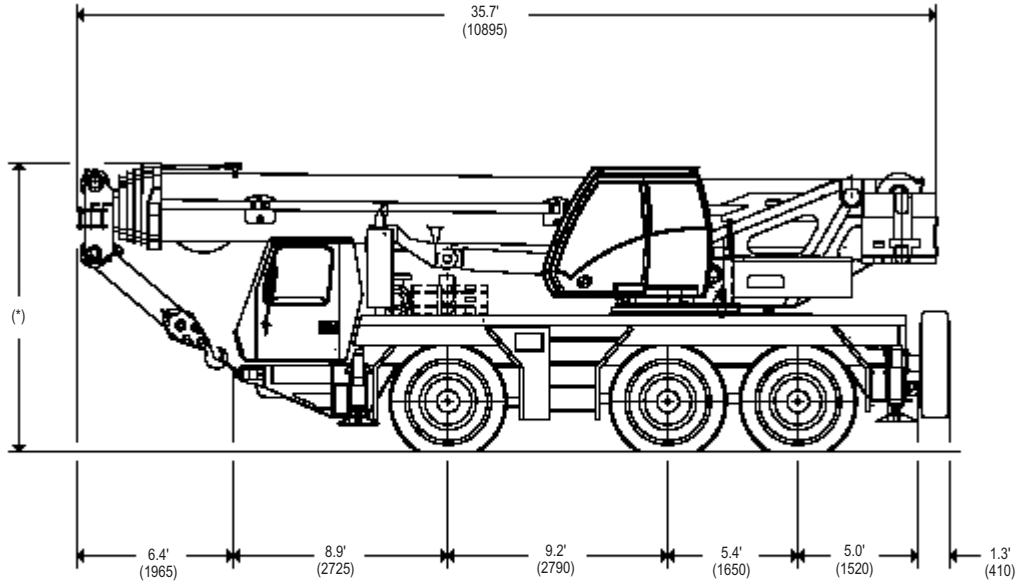

(* Travel Height +6.7'/-5.1' (+170/-130)
 14.00 Tires - 12.0' (3658)
 16.00/20.5 Tires - 12.2' (3718)

Basic Weights lb. (kg.)	Axle 1		Axles 2 & 3		Total	
Mercedes power, 14.00R25 tires, 6X4X6 drive/steer, 2nd oil cooler, outrigger pads, 14,373 lb. (6 520 kg) fixed counterweight and driver.	23,276	(10 558)	50,413	(22 867)	73,689	(32 971)
Additions:						
16.00R25 tires plus decking	293	(133)	584	(265)	877	(398)
20.5R25 tires plus decking	500	(227)	999	(453)	1,499	(680)
14.00R25 spare tire with bracket	-395	(-179)	979	(444)	584	(265)
16.00R25 spare tire with bracket	-480	(-218)	1,188	(539)	708	(321)
20.5R25 spare tire with bracket	-556	(-252)	1,367	(620)	811	(368)
6X6X6 drive/steer	748	(339)	46	(21)	794	(360)
Electric driveline retarder	-37	(-17)	412	(187)	375	(170)
Brackets for swingaway	156	(71)	-24	(-11)	132	(60)
Hose reel for luffing swingaway	264	(120)	-121	(-55)	143	(65)
28.5 ft. (8.7 m) swingaway	1,940	(880)	-452	(-205)	1,488	(675)
49.2 ft. (15 m) swingaway	2,246	(1 019)	-295	(-134)	1,951	(885)
Auxiliary boom nose	282	(128)	-150	(-68)	132	(60)
Auxiliary hoist	-1,138	(-516)	2,639	(1 197)	1,501	(681)
1 X 2,293 lb. (1 040 kg.) counterweight on superstructure	-1,358	(-616)	3,651	(1 656)	2,293	(1 040)
1 X 4,564 lb. (2 070 kg.) counterweight on superstructure	-2,705	(-1 227)	7,269	(3 297)	4,564	(2 070)
1 X 2,293 lb. (1 040 kg.) counterweight stowed on carrier	2,297	(1 042)	-4	(-2)	2,293	(1 040)
1 X 4,564 lb. (2 070 kg.) counterweight stowed on carrier	4,572	(2 074)	-9	(-4)	4,564	(2 070)
Removals:						
14,373 lb. (6 520 kg.) fixed counterweight	8,516	(3 863)	-22,890	(-10 383)	-14,374	(-6 520)
Outrigger floats (front and rear)	-130	(-59)	-183	(-83)	-313	(-142)

GMK3055

THIS CHART IS ONLY A GUIDE AND SHOULD NOT BE USED TO OPERATE THE CRANE. The individual crane's load chart, operating instructions and other instructional plates must be read and understood prior to operating the crane.

working range

32'-141' main boom

7

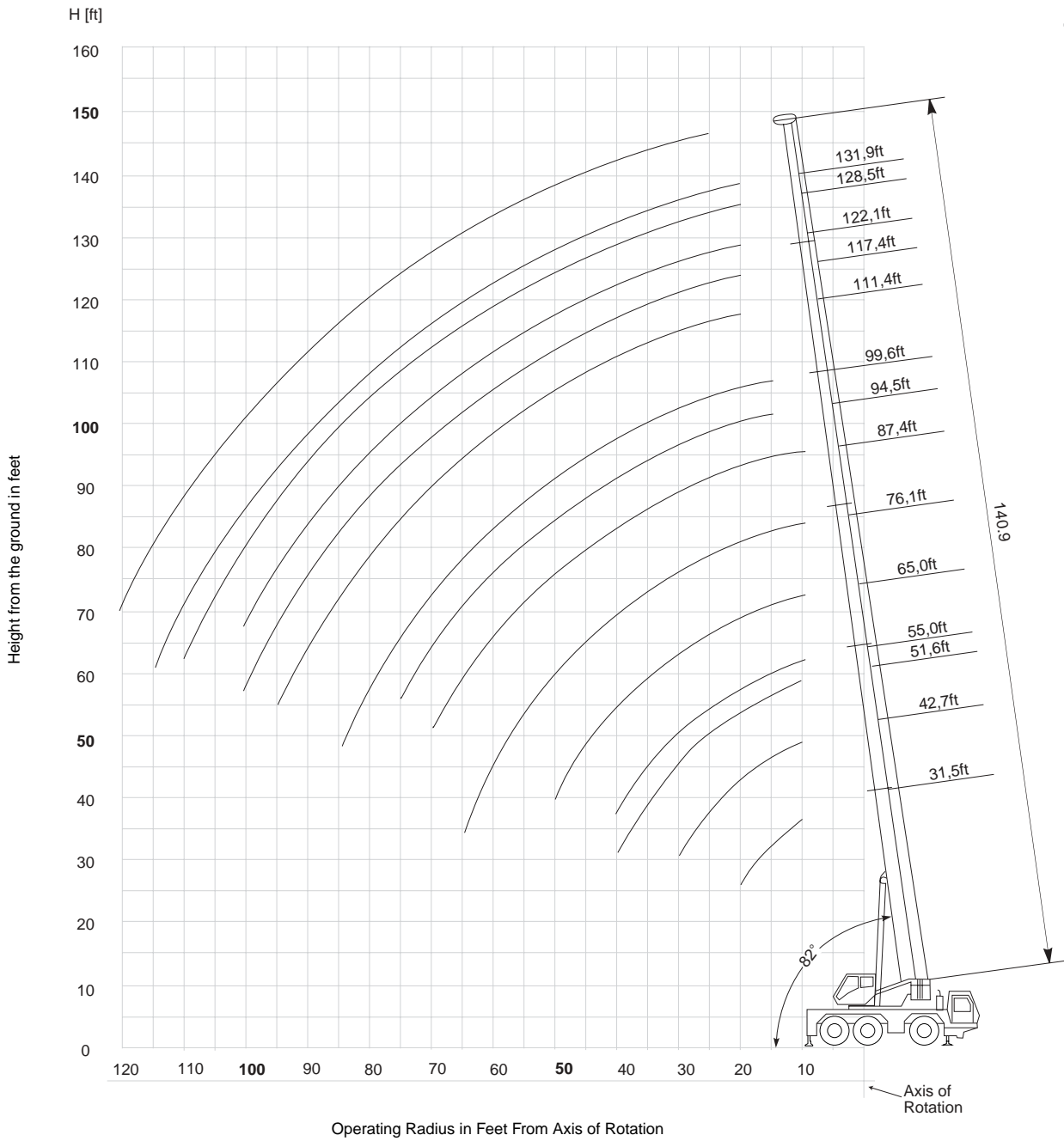

THIS CHART IS ONLY A GUIDE AND SHOULD NOT BE USED TO OPERATE THE CRANE. The individual crane's load chart, operating instructions and other instructional plates must be read and understood prior to operating the crane.

GMK3055

GROVE

load charts



8



Feet	32'	43'	51'-55'	65.0'	72'-78'	87'-95'	99'-112'	117'-123'	128'-132'	141'
10	103.0	97.0	91.0	87.0	74.0	54.0				
15	79.0	77.0	74.0	71.0	64.0	47.0	42.0			
20	60.0	61.0	60.0	58.0	54.0	41.0	36.8	26.2	20.8	
25		47.0	46.0	43.0	42.2	36.2	32.0	25.6	20.8	17.6
30		36.6	35.6	35.0	32.8	32.2	27.2	23.6	20.8	17.6
35			29.6	28.4	26.6	26.6	23.4	21.2	19.2	17.6
40			23.8	23.6	23.8	22.2	20.8	19.2	17.8	16.4
45				19.6	20.2	18.8	17.6	16.8	16.4	15.2
50				17.4	17.2	16.2	15.0	14.4	14.6	14.2
55					14.8	14.0	13.0	12.4	12.6	12.8
60					12.8	12.2	11.2	10.8	11.0	11.2
65					11.2	10.4	9.8	9.4	9.8	9.8
70						9.0	8.4	8.4	9.2	8.6
75						7.4	7.2	7.8	8.4	7.6
80							6.2	7.2	7.6	6.8
85							5.2	6.6	6.8	6.0
90							4.4	6.2	6.0	5.2
95							3.8	5.4	5.2	4.6
100								4.8	4.6	4.0
105									4.0	3.6
110									3.6	3.0
115									2.2	2.6
120										2.2



Feet	32'	43'	51'-55'	65.0'	72'-78'	87'-95'	99'-112'	117'-123'	128'-132'	141'
10	103.0	97.0	91.0	87.0	74.0	54.0				
15	79.0	77.0	74.0	71.0	64.0	47.0	42.0			
20	59.0	60.0	59.0	56.0	54.0	41.0	36.8	26.2	20.8	
25		47.0	44.0	41.2	40.4	36.2	32.0	25.6	20.8	17.6
30		35.0	35.4	33.6	31.4	31.2	27.2	23.6	20.8	17.6
35			28.4	27.2	26.4	25.4	23.4	21.2	19.2	17.6
40			22.8	22.4	22.6	21.2	19.8	18.8	17.8	16.4
45				19.0	19.2	18.0	16.6	16.0	16.0	15.2
50				16.8	16.4	15.4	14.2	13.6	13.8	13.8
55					14.0	13.4	12.2	11.8	12.4	12.0
60					12.2	11.4	10.4	10.2	11.0	10.4
65					10.4	9.8	9.0	9.0	9.8	9.2
70						8.4	7.8	8.4	8.8	8.0
75						7.4	6.6	7.8	7.8	7.0
80							5.6	7.2	7.0	6.2
85							4.8	6.6	6.2	5.4
90							4.0	5.8	5.4	4.8
95							3.4	5.0	4.8	4.2
100								4.4	4.2	3.6
105									3.6	3.2
110									3.2	2.6
115									1.8	2.2
120										1.8

GMK3055

THIS CHART IS ONLY A GUIDE AND SHOULD NOT BE USED TO OPERATE THE CRANE. The individual crane's load chart, operating instructions and other instructional plates must be read and understood prior to operating the crane.

load charts

 32-141 ft.
  21,100 lb.
  100% 20.3'
  360°



 Pounds x 1000

9

Feet	32'	43'	51'-55'	65.0'	72'-78'	87'-95'	99'-112'	117'-123'	128'-132'	141'
10	103.0	97.0	91.0	87.0	74.0	54.0				
15	79.0	77.0	74.0	71.0	64.0	47.0	42.0			
20	59.0	59.0	57.0	54.0	52.0	41.0	36.8	26.2	20.8	
25		45.0	42.2	41.2	38.6	36.2	32.0	25.6	20.8	17.6
30		33.8	33.8	32.0	30.0	29.8	27.2	23.6	20.8	17.6
35			27.0	25.8	26.0	24.2	22.6	21.2	19.2	17.6
40			21.6	21.4	21.6	20.2	18.8	17.8	17.8	16.4
45				17.6	18.4	17.0	15.8	15.0	15.2	15.2
50				16.0	15.6	14.6	13.4	12.8	13.6	13.0
55					13.2	12.4	11.4	11.4	12.2	11.2
60					11.4	10.8	9.8	10.2	10.6	9.8
65					9.8	9.2	8.4	9.0	9.4	8.6
70						8.0	7.2	8.4	8.2	7.4
75						7.4	6.0	7.8	7.2	6.4
80							5.2	6.8	6.4	5.6
85							4.2	6.0	5.8	5.0
90							3.6	5.2	5.0	4.4
95							2.8	4.6	4.4	3.8
100								4.0	3.8	3.2
105									3.2	2.8
110									2.8	2.2
115									1.4	1.8
120										1.4

 32-141 ft.
  18,900 lb.
  100% 20.3'
  360°



 Pounds x 1000

Feet	32'	43'	51'-55'	65.0'	72'-78'	87'-95'	99'-112'	117'-123'	128'-132'	141'
10	103.0	97.0	91.0	87.0	74.0	54.0				
15	78.0	77.0	74.0	71.0	64.0	47.0	42.0			
20	58.0	58.0	55.0	51.0	49.0	41.0	36.8	26.2	20.8	
25		42.8	40.6	39.4	36.8	36.2	32.0	25.6	20.8	17.6
30		32.4	32.2	30.4	29.6	28.4	26.4	23.6	20.8	17.6
35			25.8	24.6	24.6	23.0	21.4	20.2	19.2	17.6
40			20.6	20.8	20.6	19.0	17.6	16.8	16.8	16.4
45				18.0	17.4	16.0	14.8	14.2	15.0	14.2
50				15.2	14.8	13.6	12.4	12.6	13.2	12.2
55					12.4	11.6	10.6	11.4	11.4	10.4
60					10.6	10.0	9.0	10.2	10.0	9.0
65					9.2	8.8	7.6	9.0	8.6	7.8
70						8.0	6.6	8.0	7.6	6.8
75						7.4	5.4	7.2	6.8	6.0
80							4.6	6.4	6.0	5.2
85							3.8	5.6	5.2	4.4
90							3.0	4.8	4.6	3.8
95							2.4	4.2	4.0	3.4
100								3.6	3.4	2.8
105									2.8	2.4
110									2.4	1.8
115										1.4

GMK3055

THIS CHART IS ONLY A GUIDE AND SHOULD NOT BE USED TO OPERATE THE CRANE. The individual crane's load chart, operating instructions and other instructional plates must be read and understood prior to operating the crane.

load charts

10

 32-141 ft.
  16,700 lb.
  100% 20.3'
  360°

 Pounds x 1000

Feet	32'	43'	51'-55'	65.0'	72'-78'	87'-95'	99'-112'	117'-123'	128'-132'	141'
10	102.0	97.0	91.0	87.0	74.0	54.0				
15	78.0	77.0	74.0	71.0	64.0	47.0	42.0			
20	57.0	57.0	53.0	49.0	47.0	41.0	36.8	26.2	20.8	
25		40.8	39.8	37.6	35.0	34.4	32.0	25.6	20.8	17.6
30		30.6	30.6	29.0	28.8	27.0	25.0	23.6	20.8	17.6
35			24.4	23.4	23.4	21.8	20.2	19.2	19.0	17.6
40			19.4	20.6	19.4	18.0	16.6	15.8	16.4	15.8
45				17.0	16.4	15.0	13.8	14.2	14.4	13.4
50				14.2	13.8	12.6	11.6	12.6	12.4	11.4
55					11.6	10.8	9.8	11.2	10.6	9.8
60					10.0	9.4	8.2	9.8	9.2	8.4
65					8.4	8.8	7.0	8.6	8.0	7.2
70						8.0	6.0	7.4	7.0	6.2
75						7.2	5.0	6.6	6.2	5.4
80							4.0	5.8	5.4	4.6
85							3.2	5.0	4.6	4.0
90							2.6	4.4	4.0	3.4
95							2.0	3.8	3.4	2.8
100								3.2	3.0	2.4
105									2.4	2.0
110									2.0	1.6
115										
120										

 32-141 ft.
  14,500 lb.
  100% 20.3'
  360°

 Pounds x 1000

Feet	32'	43'	51'-55'	65.0'	72'-78'	87'-95'	99'-112'	117'-123'	128'-132'	141'
10	102.0	97.0	91.0	87.0	74.0	54.0				
15	78.0	77.0	74.0	71.0	64.0	47.0	42.0			
20	56.0	54.0	50.0	49.0	45.0	41.0	36.8	26.2	20.8	
25		38.6	37.8	35.6	33.6	32.8	30.4	25.6	20.8	17.6
30		29.0	29.0	27.4	27.4	25.6	23.6	22.2	20.8	17.6
35			23.0	23.4	22.2	20.6	19.0	18.0	17.8	17.6
40			18.2	19.4	18.2	16.8	15.4	15.8	16.0	14.8
45				16.0	15.2	14.0	12.8	14.2	13.4	12.4
50				13.2	13.0	11.8	10.6	12.0	11.4	10.6
55					10.8	10.6	8.8	10.4	9.8	9.0
60					9.2	9.4	7.4	9.0	8.6	7.6
65					7.8	8.8	6.2	7.8	7.4	6.6
70						7.6	5.4	6.8	6.4	5.6
75						6.6	4.4	6.0	5.6	4.8
80							3.6	5.2	4.8	4.0
85							2.8	4.6	4.2	3.4
90							2.2	3.8	3.6	2.8
95							1.6	3.4	3.0	2.4
100								2.8	2.6	2.0
105									2.2	1.6
110									1.8	
115										
120										

GMK3055

THIS CHART IS ONLY A GUIDE AND SHOULD NOT BE USED TO OPERATE THE CRANE. The individual crane's load chart, operating instructions and other instructional plates must be read and understood prior to operating the crane.

working range

32'-141' main boom with 28.5 ft. and 49.2 ft. swingaway

11

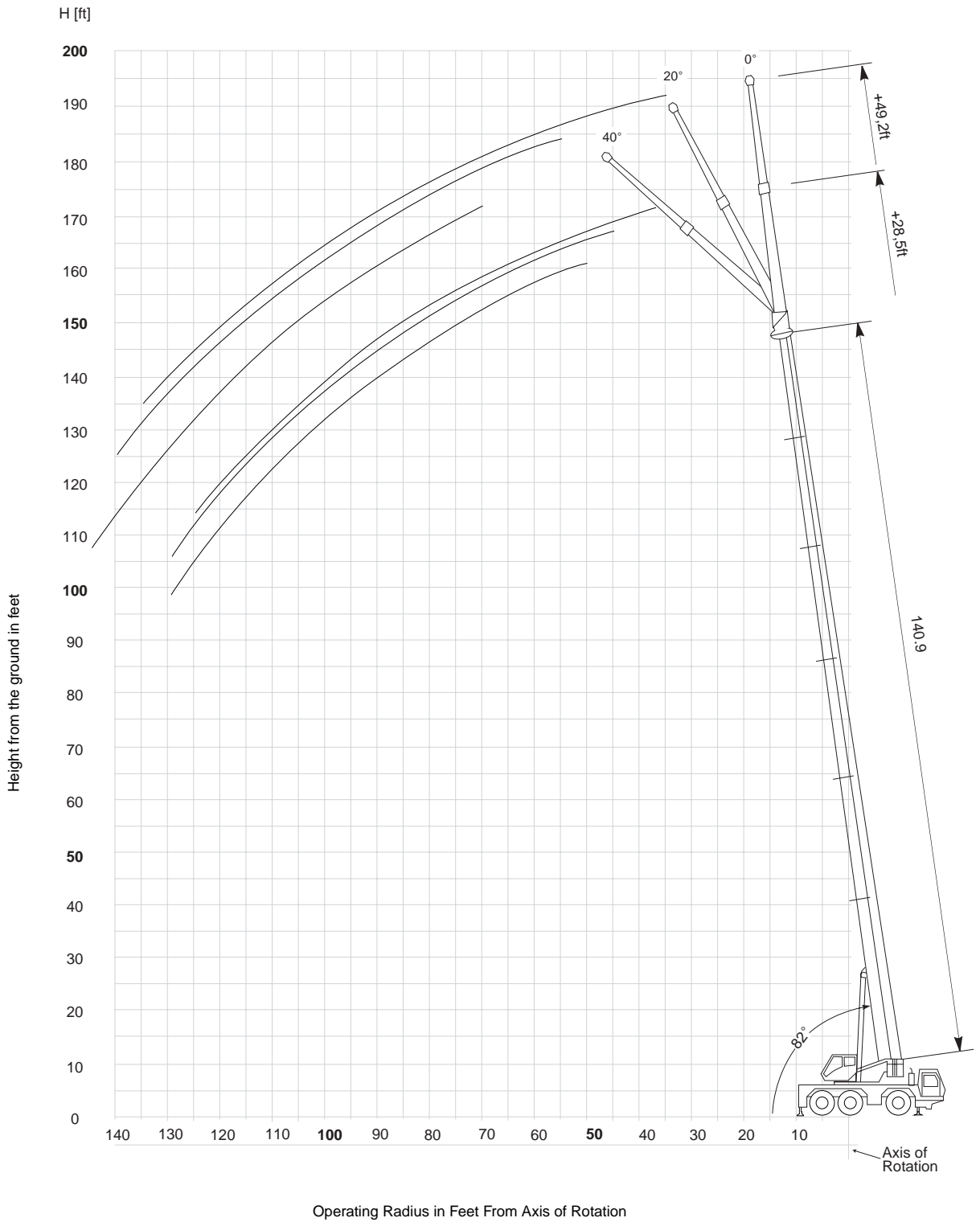

GMK3055

THIS CHART IS ONLY A GUIDE AND SHOULD NOT BE USED TO OPERATE THE CRANE. The individual crane's load chart, operating instructions and other instructional plates must be read and understood prior to operating the crane.

load charts

12



Pounds x 1000
28.5 ft. Length

Feet	0° Offset					40° Offset				
	87.4	99.6	117.4	128.5	140.9	87.4	99.6	117.4	128.5	140.9
20.0	17.4	17.0								
25.0	16.0	16.0	12.4							
30.0	14.6	15.0	12.4	9.2						
35.0	13.6	14.0	12.0	9.2	9.4	8.0				
40.0	12.6	13.2	11.0	9.2	9.4	7.8	7.8			
45.0	11.4	12.4	10.0	9.2	9.4	7.6	7.6	7.6		
50.0	10.4	11.6	9.0	9.2	9.4	7.4	7.6	7.4	7.4	7.4
55.0	10.0	10.8	8.4	8.6	8.8	7.2	7.4	7.4	7.4	7.4
60.0	9.4	10.2	7.8	8.0	8.2	7.2	7.2	7.2	7.2	7.2
65.0	8.8	9.4	7.2	7.6	7.8	7.0	7.2	6.8	7.0	7.2
70.0	8.4	8.6	6.8	7.0	7.4	7.0	7.0	6.4	6.6	6.8
75.0	8.0	7.6	6.4	6.6	7.0	7.0	7.0	6.2	6.4	6.6
80.0	7.6	6.8	6.0	6.4	6.2	7.0	7.0	5.8	6.0	6.2
85.0	6.8	6.0	5.6	6.0	5.6	7.0	6.6	5.6	5.8	6.0
90.0	6.0	5.2	5.2	5.6	4.8	6.2	5.6	5.2	5.6	5.6
95.0	5.2	4.4	4.8	5.0	4.2	5.4	4.8	5.0	5.2	4.8
100.0	4.6	3.8	4.4	4.4	3.8		4.2	4.6	5.0	4.2
105.0		3.2	4.2	4.0	3.2		3.4	4.4	4.4	3.8
110.0		2.8	3.8	3.4	2.8		2.8	4.0	3.8	3.2
115.0			3.4	3.0	2.4			3.6	3.4	2.8
120.0			3.0	2.6	2.0			3.0	2.8	2.4
125.0			2.6	2.2	1.6				2.4	2.0
130.0			2.2	1.8					2.0	1.4
135.0				1.6					1.6	

3 085 970

3 085 972

GMK3055

THIS CHART IS ONLY A GUIDE AND SHOULD NOT BE USED TO OPERATE THE CRANE. The individual crane's load chart, operating instructions and other instructional plates must be read and understood prior to operating the crane.

load charts



32-141 ft.
49.2 ft. Manual Offset
25,500 lb.
100% 20.3'
360°

Feet

Pounds x 1000
49.2 ft. Length

13

	0° Offset					40° Offset				
	87.4	99.6	117.4	128.5	140.9	87.4	99.6	117.4	128.5	140.9
20.0	9.2									
25.0	8.8	8.4								
30.0	8.4	8.2	6.6	5.8						
35.0	7.8	7.8	6.6	5.8	5.6					
40.0	7.2	7.4	6.4	5.8	5.6					
45.0	6.8	7.0	6.4	5.8	5.6					
50.0	6.2	6.4	6.2	5.8	5.6	4.0				
55.0	6.0	6.2	6.0	5.8	5.6	4.0	4.0			
60.0	5.6	5.8	5.8	5.8	5.4	3.8	3.8	3.8		
65.0	5.2	5.6	5.4	5.6	5.4	3.8	3.8	3.8		
70.0	5.0	5.2	5.2	5.4	5.4	3.6	3.8	3.8	3.8	3.8
75.0	4.8	5.0	5.0	5.2	5.2	3.6	3.6	3.6	3.6	3.6
80.0	4.6	4.8	4.8	5.0	5.0	3.6	3.6	3.6	3.6	3.6
85.0	4.4	4.6	4.6	4.8	4.8	3.4	3.6	3.6	3.6	3.6
90.0	4.2	4.4	4.4	4.6	4.6	3.4	3.4	3.4	3.4	3.6
95.0	4.0	4.2	4.2	4.4	4.6	3.4	3.4	3.4	3.4	3.4
100.0	3.8	4.0	4.0	4.2	4.0	3.4	3.4	3.4	3.4	3.4
105.0	3.8	4.0	3.8	4.0	3.6	3.4	3.4	3.4	3.4	3.4
110.0	3.6	3.4	3.6	3.8	3.2	3.4	3.4	3.4	3.4	3.4
115.0	3.6	3.0	3.4	3.4	2.8	3.4	3.4	3.4	3.4	3.4
120.0	3.4	2.6	3.2	3.0	2.4		3.0	3.2	3.4	3.2
125.0		2.2	3.0	2.6	2.0		2.6	3.2	3.2	2.8
130.0		1.8	2.6	2.2	1.6		2.0	3.0	2.8	2.4
135.0				2.0	1.4				2.4	2.0
140.0				1.6					2.0	1.6
145.0				1.4					1.6	1.4
150.0									1.4	

3 085 973

3 085 975

GMK3055

THIS CHART IS ONLY A GUIDE AND SHOULD NOT BE USED TO OPERATE THE CRANE. The individual crane's load chart, operating instructions and other instructional plates must be read and understood prior to operating the crane.

load charts

14



32-141 ft.



28.5 ft.
Manual Offset



16,700 lb.



100%
20.3'



360°



Feet

Pounds x 1000

28.5 ft. Length

	0° Offset					40° Offset				
	87.4	99.6	117.4	128.5	140.9	87.4	99.6	117.4	128.5	140.9
20.0	17.4	17.0								
25.0	16.0	16.0	12.4							
30.0	14.6	15.0	12.4	9.2						
35.0	13.6	14.0	12.0	9.2	9.4	8.0				
40.0	12.6	13.2	11.0	9.2	9.4	7.8	7.8			
45.0	11.4	12.4	10.0	9.2	9.4	7.6	7.6	7.6		
50.0	10.4	11.6	9.0	9.2	9.4	7.4	7.6	7.4	7.4	7.4
55.0	10.0	9.8	8.4	8.6	8.8	7.2	7.4	7.4	7.4	7.4
60.0	9.4	8.4	7.8	8.0	7.8	7.2	7.2	7.2	7.2	7.2
65.0	8.4	7.2	7.2	7.6	6.6	7.0	7.2	6.8	7.0	7.2
70.0	7.2	6.2	6.8	6.6	5.8	7.0	7.0	6.4	6.6	6.8
75.0	6.4	5.4	6.2	5.6	5.0	7.0	6.2	6.2	6.4	5.8
80.0	5.6	4.6	5.4	5.0	4.2	6.0	5.2	5.8	5.8	5.0
85.0	4.8	3.8	4.8	4.2	3.6	5.2	4.4	5.4	5.0	4.4
90.0	4.0	3.2	4.2	3.8	3.0	4.4	3.8	4.8	4.4	3.6
95.0	3.4	2.6	3.6	3.2	2.4	3.6	3.0	4.2	3.8	3.2
100.0	3.0	2.2	3.2	2.8	2.0		2.4	3.6	3.2	2.6
105.0		1.6	2.8	2.4	1.6		1.8	3.0	2.8	2.2
110.0			2.4	2.0			1.2	2.6	2.2	1.6
115.0			2.0	1.6				2.2	1.8	
120.0			1.6					1.8	1.4	

3 086 010

3 086 012

GMK3055

THIS CHART IS ONLY A GUIDE AND SHOULD NOT BE USED TO OPERATE THE CRANE. The individual crane's load chart, operating instructions and other instructional plates must be read and understood prior to operating the crane.

GROVE

load charts



Pounds x 1000
49.2 ft. Length

15

	0° Offset					40° Offset				
	87.4	99.6	117.4	128.5	140.9	87.4	99.6	117.4	128.5	140.9
20.0	9.2									
25.0	8.8	8.4								
30.0	8.4	8.2	6.6	5.8						
35.0	7.8	7.8	6.6	5.8	5.6					
40.0	7.2	7.4	6.4	5.8	5.6					
45.0	6.8	7.0	6.4	5.8	5.6					
50.0	6.2	6.4	6.2	5.8	5.6	4.0				
55.0	6.0	6.2	6.0	5.8	5.6	4.0	4.0			
60.0	5.6	5.8	5.8	5.8	5.4	3.8	3.8	3.8		
65.0	5.2	5.6	5.4	5.6	5.4	3.8	3.8	3.8		
70.0	5.0	5.2	5.2	5.4	5.4	3.6	3.8	3.8	3.8	3.8
75.0	4.8	5.0	5.0	5.2	5.2	3.6	3.6	3.6	3.6	3.6
80.0	4.6	4.8	4.8	5.0	4.6	3.6	3.6	3.6	3.6	3.6
85.0	4.4	4.4	4.6	4.6	4.0	3.4	3.6	3.6	3.6	3.6
90.0	4.2	3.8	4.4	4.0	3.4	3.4	3.4	3.4	3.4	3.6
95.0	4.0	3.4	4.0	3.6	2.8	3.4	3.4	3.4	3.4	3.4
100.0	3.6	2.8	3.6	3.0	2.4	3.4	3.4	3.4	3.4	3.4
105.0	3.2	2.4	3.2	2.6	2.0	3.4	3.2	3.4	3.4	3.0
110.0	2.8	2.0	2.8	2.2	1.6	3.2	2.8	3.4	3.2	2.6
115.0	2.4	1.6	2.4	2.0		2.6	2.2	3.0	2.8	2.2
120.0	2.0		2.0	1.6			1.6	2.6	2.4	1.8
125.0			1.8	1.4				2.2	2.0	1.4
130.0			1.4					1.8	1.6	

3 086 013

3 086 015

GMK3055

THIS CHART IS ONLY A GUIDE AND SHOULD NOT BE USED TO OPERATE THE CRANE. The individual crane's load chart, operating instructions and other instructional plates must be read and understood prior to operating the crane.

load charts

16

- 32-141 ft.
- 28.5 ft.
Hydraulic Luffing
- 25,500 lb.
- 100%
20.3'
- 360°

Feet	Pounds x 1000									
	28.5 ft. Length									
	0° Offset					20°-40° Offset (intermediate angle)				
	87.4	99.6	117.4	128.5	140.9	87.4	99.6	117.4	128.5	140.9
20.0	17.4	17.0								
25.0	16.0	16.0	12.4							
30.0	14.6	15.0	12.4	9.2						
35.0	13.6	14.0	12.0	9.2	9.4	8.0				
40.0	12.6	13.2	11.0	9.2	9.4	7.8	7.8			
45.0	11.4	12.4	10.0	9.2	9.4	7.6	7.6	7.6		
50.0	10.4	11.6	9.0	9.2	9.4	7.4	7.6	7.4	7.4	7.4
55.0	10.0	10.8	8.4	8.6	8.8	7.2	7.4	7.4	7.4	7.4
60.0	9.4	10.2	7.8	8.0	8.2	7.2	7.2	7.2	7.2	7.2
65.0	8.8	9.4	7.2	7.6	7.8	7.0	7.2	6.8	7.0	7.2
70.0	8.4	8.6	6.8	7.0	7.4	7.0	7.0	6.4	6.6	6.8
75.0	8.0	7.6	6.4	6.6	7.0	7.0	7.0	6.2	6.4	6.6
80.0	7.6	6.8	6.0	6.4	6.2	7.0	7.0	5.8	6.0	6.2
85.0	6.8	6.0	5.6	6.0	5.6	7.0	6.4	5.6	5.8	6.0
90.0	6.0	5.2	5.2	5.6	4.8	6.2	5.6	5.2	5.6	5.2
95.0	5.2	4.4	4.8	5.0	4.2	5.4	4.8	5.0	5.2	4.6
100.0	4.6	3.8	4.4	4.4	3.8		4.0	4.6	4.8	4.0
105.0		3.2	4.2	4.0	3.2		3.4	4.4	4.2	3.6
110.0		2.8	3.8	3.4	2.8		2.8	4.0	3.8	3.0
115.0			3.4	3.0	2.4			3.6	3.2	2.6
120.0			3.0	2.6	2.0			3.0	2.8	2.2
125.0			2.6	2.2	1.6				2.4	1.8
130.0			2.2	1.8					2.0	1.4
135.0				1.6					1.6	

3 085 970

3 094 272

GMK3055

THIS CHART IS ONLY A GUIDE AND SHOULD NOT BE USED TO OPERATE THE CRANE. The individual crane's load chart, operating instructions and other instructional plates must be read and understood prior to operating the crane.

load charts



Feet

Pounds x 1000
28.5 ft. Length

17

	0°-20° Offset (loads for luffing)					20°-40° Offset (loads for luffing)				
	87.4	99.6	117.4	128.5	140.9	87.4	99.6	117.4	128.5	140.9
30.0	5.6	5.8								
35.0	5.2	5.4				4.2				
40.0	5.0	5.2	5.4	5.6		4.2	4.2			
45.0	4.6	4.8	5.2	5.2	5.4	4.0	4.0	4.2		
50.0	4.4	4.6	4.8	5.0	5.2	4.0	4.0	4.0	4.2	4.2
55.0	4.2	4.4	4.6	4.8	5.0	3.8	3.8	4.0	4.0	4.0
60.0	4.0	4.2	4.4	4.6	4.8	3.8	3.8	3.8	4.0	4.0
65.0	3.8	4.0	4.4	4.4	4.6	3.6	3.8	3.8	3.8	3.8
70.0	3.8	4.0	4.2	4.2	4.4	3.6	3.6	3.8	3.8	3.8
75.0	3.6	3.8	4.0	4.2	4.2	3.6	3.6	3.6	3.8	3.8
80.0	3.4	3.6	3.8	4.0	4.2	3.4	3.6	3.6	3.6	3.8
85.0	3.4	3.6	3.8	3.8	4.0	3.4	3.6	3.6	3.6	3.6
90.0	3.2	3.4	3.6	3.8	4.0	3.4	3.4	3.6	3.6	3.6
95.0	3.0	3.4	3.6	3.6	3.8	3.2	3.4	3.6	3.6	3.6
100.0	3.0	3.2	3.4	3.6	3.6		3.4	3.4	3.6	3.6
105.0		3.0	3.4	3.6	3.2		3.2	3.4	3.6	3.4
110.0		2.6	3.4	3.2	2.6		2.6	3.4	3.4	3.0
115.0		2.2	3.0	2.8	2.2			3.2	3.0	2.4
120.0			2.6	2.4	1.8			2.8	2.6	2.0
125.0			2.4	2.0	1.6				2.2	1.6
130.0			2.0	1.6					1.8	1.4
135.0				1.4					1.4	

3 094 273

3 094 274

GMK3055

THIS CHART IS ONLY A GUIDE AND SHOULD NOT BE USED TO OPERATE THE CRANE. The individual crane's load chart, operating instructions and other instructional plates must be read and understood prior to operating the crane.

load charts

18



32-141 ft.



49.2 ft.
Hydraulic Luffing



25,500 lb.



100%
20.3'



360°



Feet

Pounds x 1000

49.2 ft. Length

	0° Offset					20°-40° Offset (intermediate angle)				
	87.4	99.6	117.4	128.5	140.9	87.4	99.6	117.4	128.5	140.9
20.0	9.2									
25.0	8.8	8.4								
30.0	8.4	8.2	6.6	5.8						
35.0	7.8	7.8	6.6	5.8	5.6					
40.0	7.2	7.4	6.4	5.8	5.6					
45.0	6.8	7.0	6.4	5.8	5.6					
50.0	6.2	6.4	6.2	5.8	5.6	4.0				
55.0	6.0	6.2	6.0	5.8	5.6	4.0	4.0			
60.0	5.6	5.8	5.8	5.8	5.4	3.8	3.8	3.8		
65.0	5.2	5.6	5.4	5.6	5.4	3.8	3.8	3.8		
70.0	5.0	5.2	5.2	5.4	5.4	3.6	3.8	3.8	3.8	3.8
75.0	4.8	5.0	5.0	5.2	5.2	3.6	3.6	3.6	3.6	3.6
80.0	4.6	4.8	4.8	5.0	5.0	3.6	3.6	3.6	3.6	3.6
85.0	4.4	4.6	4.6	4.8	4.8	3.4	3.6	3.6	3.6	3.6
90.0	4.2	4.4	4.4	4.6	4.6	3.4	3.4	3.4	3.4	3.6
95.0	4.0	4.2	4.2	4.4	4.6	3.4	3.4	3.4	3.4	3.4
100.0	3.8	4.0	4.0	4.2	4.0	3.4	3.4	3.4	3.4	3.4
105.0	3.8	4.0	3.8	4.0	3.6	3.4	3.4	3.4	3.4	3.4
110.0	3.6	3.4	3.6	3.8	3.2	3.4	3.4	3.4	3.4	3.4
115.0	3.6	3.0	3.4	3.4	2.8	3.4	3.4	3.4	3.4	3.2
120.0	3.4	2.6	3.2	3.0	2.4		3.0	3.2	3.4	2.8
125.0		2.2	3.0	2.6	2.0			3.2	3.0	2.4
130.0		1.8	2.6	2.2	1.6			3.0	2.6	2.2
135.0				2.0	1.4				2.4	1.8
140.0				1.6					2.0	1.4
145.0				1.4					1.6	
150.0									1.4	

3 085 973

3 094 277

GMK3055

THIS CHART IS ONLY A GUIDE AND SHOULD NOT BE USED TO OPERATE THE CRANE. The individual crane's load chart, operating instructions and other instructional plates must be read and understood prior to operating the crane.

GROVE

load charts



Pounds x 1000
49.2 ft. Length

19

Feet	0°-20° Offset (loads for luffing)					20°-40° Offset (loads for luffing)				
	87.4	99.6	117.4	128.5	140.9	87.4	99.6	117.4	128.5	140.9
40.0	2.8	3.0								
45.0	2.6	2.8								
50.0	2.4	2.6	2.8	2.8		2.0				
55.0	2.4	2.4	2.6	2.6	2.8	2.0	2.0			
60.0	2.2	2.4	2.4	2.6	2.6	1.8	2.0	2.0		
65.0	2.0	2.2	2.4	2.4	2.4	1.8	1.8	1.8		
70.0	2.0	2.0	2.2	2.2	2.4	1.8	1.8	1.8	1.8	1.8
75.0	1.8	2.0	2.2	2.2	2.2	1.8	1.8	1.8	1.8	1.8
80.0	1.8	1.8	2.0	2.2	2.2	1.6	1.6	1.8	1.8	1.8
85.0	1.8	1.8	2.0	2.0	2.0	1.6	1.6	1.8	1.8	1.8
90.0	1.6	1.8	1.8	2.0	2.0	1.6	1.6	1.6	1.6	1.8
95.0	1.6	1.6	1.8	1.8	2.0	1.6	1.6	1.6	1.6	1.6
100.0	1.6	1.6	1.8	1.8	1.8	1.6	1.6	1.6	1.6	1.6
105.0	1.4	1.6	1.6	1.8	1.8	1.4	1.6	1.6	1.6	1.6
110.0	1.4	1.6	1.6	1.6	1.8	1.4	1.6	1.6	1.6	1.6
115.0	1.4	1.4	1.6	1.6	1.6	1.4	1.4	1.6	1.6	1.6
120.0		1.4	1.6	1.6	1.6		1.4	1.6	1.6	1.6
125.0		1.4	1.4	1.6	1.6			1.4	1.6	1.6
130.0			1.4	1.6	1.6			1.4	1.6	1.6
135.0				1.4	1.4				1.4	1.6
140.0				1.4					1.4	1.4
145.0									1.4	

3 094 278

3 094 279

GMK3055

THIS CHART IS ONLY A GUIDE AND SHOULD NOT BE USED TO OPERATE THE CRANE. The individual crane's load chart, operating instructions and other instructional plates must be read and understood prior to operating the crane.

load charts

20



32-141 ft.



28.5 ft.
Hydraulic Luffing



16,700 lb.



100%
20.3'



360°



Feet

Pounds x 1000

28.5 ft. Length

	0° Offset					20°-40° Offset (intermediate angle)				
	87.4	99.6	117.4	128.5	140.9	87.4	99.6	117.4	128.5	140.9
20.0	17.4	17.0								
25.0	16.0	16.0	12.4							
30.0	14.6	15.0	12.4	9.2						
35.0	13.6	14.0	12.0	9.2	9.4	8.0				
40.0	12.6	13.2	11.0	9.2	9.4	7.8	7.8			
45.0	11.4	12.4	10.0	9.2	9.4	7.6	7.6	7.6		
50.0	10.4	11.6	9.0	9.2	9.4	7.4	7.6	7.4	7.4	7.4
55.0	10.0	9.8	8.4	8.6	8.8	7.2	7.4	7.4	7.4	7.4
60.0	9.4	8.4	7.8	8.0	7.8	7.2	7.2	7.2	7.2	7.2
65.0	8.4	7.2	7.2	7.6	6.6	7.0	7.2	6.8	7.0	7.2
70.0	7.2	6.2	6.8	6.6	5.8	7.0	6.8	6.4	6.6	6.4
75.0	6.4	5.4	6.2	5.6	5.0	6.8	5.8	6.2	6.2	5.4
80.0	5.6	4.6	5.4	5.0	4.2	6.0	5.0	5.8	5.4	4.6
85.0	4.8	3.8	4.8	4.2	3.6	5.0	4.2	5.2	4.6	4.0
90.0	4.0	3.2	4.2	3.8	3.0	4.4	3.6	4.6	4.0	3.4
95.0	3.4	2.6	3.6	3.2	2.4	3.6	3.0	4.0	3.6	2.8
100.0	3.0	2.2	3.2	2.8	2.0		2.4	3.4	3.0	2.4
105.0		1.6	2.8	2.4	1.6		1.8	3.0	2.6	2.0
110.0			2.4	2.0			1.4	2.6	2.2	1.6
115.0			2.0	1.6				2.2	1.8	
120.0			1.6					1.8	1.4	

3 086 010

3 094 312

GMK3055

THIS CHART IS ONLY A GUIDE AND SHOULD NOT BE USED TO OPERATE THE CRANE. The individual crane's load chart, operating instructions and other instructional plates must be read and understood prior to operating the crane.

GROVE

load charts



Pounds x 1000
28.5 ft. Length

21

	0°-20° Offset (loads for luffing)					20°-40° Offset (loads for luffing)				
	87.4	99.6	117.4	128.5	140.9	87.4	99.6	117.4	128.5	140.9
30.0	5.6	5.8								
35.0	5.2	5.4				4.2				
40.0	5.0	5.2	5.4	5.6		4.2	4.2			
45.0	4.6	4.8	5.2	5.2	5.4	4.0	4.0	4.2		
50.0	4.4	4.6	4.8	5.0	5.2	4.0	4.0	4.0	4.2	4.2
55.0	4.2	4.4	4.6	4.8	5.0	3.8	3.8	4.0	4.0	4.0
60.0	4.0	4.2	4.4	4.6	4.8	3.8	3.8	3.8	4.0	4.0
65.0	3.8	4.0	4.4	4.4	4.6	3.6	3.8	3.8	3.8	3.8
70.0	3.8	4.0	4.2	4.2	4.4	3.6	3.6	3.8	3.8	3.8
75.0	3.6	3.8	4.0	4.2	4.2	3.6	3.6	3.6	3.8	3.8
80.0	3.4	3.6	3.8	4.0	4.2	3.4	3.6	3.6	3.6	3.8
85.0	3.4	3.6	3.8	3.8	3.6	3.4	3.6	3.6	3.6	3.6
90.0	3.2	3.0	3.6	3.6	3.0	3.4	3.4	3.6	3.6	3.4
95.0	3.0	2.4	3.4	3.2	2.4	3.2	2.8	3.6	3.4	2.8
100.0	2.6	2.0	3.0	2.6	2.0		2.2	3.2	3.0	2.4
105.0		1.6	2.6	2.2	1.6		1.8	2.8	2.4	2.0
110.0			2.2	1.8			1.2	2.4	2.0	1.6
115.0			1.8	1.4				2.0	1.6	
120.0			1.4					1.6	1.2	

3 094 313

3 094 314

NOTES:

- The above lifting capacity values are not monitored by the SLI. However they are within the capacity values for intermediate angle, which are monitored by the SLI.
- The loads for luffing depend on angle of main boom, angle of swingaway and dynamic working pressure of the luffing cylinder for swingaway. If the dynamic working pressure is exceeded, the SLI will cut-off the luffing-out function.

THIS CHART IS ONLY A GUIDE AND SHOULD NOT BE USED TO OPERATE THE CRANE. The individual crane's load chart, operating instructions and other instructional plates must be read and understood prior to operating the crane.

GMK3055

load charts

22



32-141 ft.



49.2 ft.
Hydraulic Luffing



16,700 lb.



100%
20.3'



360°



Feet

Pounds x 1000

49.2 ft. Length

	0° Offset					20°-40° Offset (intermediate angle)				
	87.4	99.6	117.4	128.5	140.9	87.4	99.6	117.4	128.5	140.9
20.0	9.2									
25.0	8.8	8.4								
30.0	8.4	8.2	6.6	5.8						
35.0	7.8	7.8	6.6	5.8	5.6					
40.0	7.2	7.4	6.4	5.8	5.6					
45.0	6.8	7.0	6.4	5.8	5.6					
50.0	6.2	6.4	6.2	5.8	5.6	4.0				
55.0	6.0	6.2	6.0	5.8	5.6	4.0	4.0			
60.0	5.6	5.8	5.8	5.8	5.4	3.8	3.8	3.8		
65.0	5.2	5.6	5.4	5.6	5.4	3.8	3.8	3.8		
70.0	5.0	5.2	5.2	5.4	5.4	3.6	3.8	3.8	3.8	3.8
75.0	4.8	5.0	5.0	5.2	5.2	3.6	3.6	3.6	3.6	3.6
80.0	4.6	4.8	4.8	5.0	4.6	3.6	3.6	3.6	3.6	3.6
85.0	4.4	4.4	4.6	4.6	4.0	3.4	3.6	3.6	3.6	3.6
90.0	4.2	3.8	4.4	4.0	3.4	3.4	3.4	3.4	3.4	3.6
95.0	4.0	3.4	4.0	3.6	2.8	3.4	3.4	3.4	3.4	3.4
100.0	3.6	2.8	3.6	3.0	2.4	3.4	3.4	3.4	3.4	3.0
105.0	3.2	2.4	3.2	2.6	2.0	3.4	3.0	3.4	3.2	2.6
110.0	2.8	2.0	2.8	2.2	1.6	3.0	2.4	3.2	2.8	2.2
115.0	2.4	1.6	2.4	2.0		2.6	2.0	2.8	2.4	1.8
120.0	2.0		2.0	1.6			1.6	2.4	2.0	1.4
125.0			1.8	1.4				2.0	1.6	
130.0			1.4					1.8	1.4	

3 085 013

3 094 317

GMK3055

THIS CHART IS ONLY A GUIDE AND SHOULD NOT BE USED TO OPERATE THE CRANE. The individual crane's load chart, operating instructions and other instructional plates must be read and understood prior to operating the crane.

GROVE

load charts



Feet
 Pounds x 1000
 49.2 ft. Length

23

	0°-20° Offset (loads for luffing)					20°-40° Offset (loads for luffing)				
	87.4	99.6	117.4	128.5	140.9	87.4	99.6	117.4	128.5	140.9
40.0	2.8	3.0								
45.0	2.6	2.8								
50.0	2.4	2.6	2.8	2.8		2.0				
55.0	2.4	2.4	2.6	2.6	2.8	2.0	2.0			
60.0	2.2	2.4	2.4	2.6	2.6	1.8	2.0	2.0		
65.0	2.0	2.2	2.4	2.4	2.4	1.8	1.8	1.8		
70.0	2.0	2.0	2.2	2.2	2.4	1.8	1.8	1.8	1.8	1.8
75.0	1.8	2.0	2.2	2.2	2.2	1.8	1.8	1.8	1.8	1.8
80.0	1.8	1.8	2.0	2.2	2.2	1.6	1.6	1.8	1.8	1.8
85.0	1.8	1.8	2.0	2.0	2.0	1.6	1.6	1.8	1.8	1.8
90.0	1.6	1.8	1.8	2.0	2.0	1.6	1.6	1.6	1.6	1.8
95.0	1.6	1.6	1.8	1.8	2.0	1.6	1.6	1.6	1.6	1.6
100.0	1.6	1.6	1.8	1.8	1.8	1.6	1.6	1.6	1.6	1.6
105.0	1.4	1.6	1.6	1.8	1.8	1.4	1.6	1.6	1.6	1.6
110.0	1.4	1.6	1.6	1.6	1.6	1.4	1.6	1.6	1.6	1.6
115.0	1.4	1.4	1.6	1.6		1.4	1.4	1.6	1.6	1.6
120.0			1.6	1.6			1.4	1.6	1.6	1.4
125.0			1.4					1.4	1.6	
130.0			1.2					1.4	1.2	

3 094 318

3 094 319

GMK3055

THIS CHART IS ONLY A GUIDE AND SHOULD NOT BE USED TO OPERATE THE CRANE. The individual crane's load chart, operating instructions and other instructional plates must be read and understood prior to operating the crane.



Manitowoc Crane Group - Americas

Tel: [Int + 001] 920 684 6621
Fax: [Int + 001] 920 683 6277

Manitowoc Crane Group - EMEA

Europe Middle East & Africa
Tel: [Int + 33] (0) 191 565 6281
Fax: [Int + 33] (0) 4 72 18 20 20

Manitowoc Crane Group - UK

Europe Middle East & Africa
Tel: [Int + 44] (0) 191 565 6281
Fax: [Int + 44] (0) 191 564 0442

Manitowoc Crane Group - Germany

(Sales, Parts & Service)
Tel: [Int + 49](0) 2173 8909 0
Fax: [Int + 49] (0) 2173 8909-30

Manitowoc Crane Group - France

France & Africa (Sales, Parts & Service)
Tel: [Int + 33] (0) 1 303 13150
Fax: [Int + 33] (0) 1 303 86085

Manitowoc Crane Group - Netherlands

(Sales, Parts & Service)
Tel: [Int + 31] (0) 76 578 39 99
Fax: [Int + 31] (0) 76 578 39 78

Manitowoc Crane Group - Italy

Italy & Southern Europe (Sales, Parts & Service)
Tel: [Int + 39] (0) 331 49 33 11
Fax: [Int + 39] (0) 331 49 33 30

Manitowoc Crane Group - Portugal

Portugal & Spain (Sales, Parts & Service)
Tel: [Int + 351] (0) 22 968 08 89
Fax: [Int + 351] (0) 22 968 08 97

Manitowoc Crane Group - Singapore

Asia/Pacific excl China (Sales, Parts & Service)
Tel: [Int + 65] 6861 1733
Fax: [Int + 65] 6862 4040 / 4142

Manitowoc Crane Group - Shanghai

China (Sales, Parts & Service)
Tel: [Int + 86] (0) 21 64955555
Fax: [Int + 86] (0) 2164852038

Manitowoc Crane Group - Beijing

China (Sales, Parts & Service)
Tel: [Int + 86] (0) 10 646 71690
Fax: [Int + 86] (0) 10 646 71691

Manitowoc Crane Group - Middle East

Sales
Tel: [Int + 971] (0) 4 348 4478
Fax: [Int + 971] (0) 4 348 4478
(Parts & Service)
Tel: [Int + 973] (0) 9 660 899
Fax: [Int + 973] (0) 2 707 740

Distributed By:



www.manitowoccrane.com



Constant improvement and engineering progress make it necessary that we reserve the right to make specification, equipment, and price changes without notice. Illustrations shown may include optional equipment and accessories, and may not include all standard equipment.